

# F372A

## GRAPHIC DISPLAY / TOUCH PANEL TYPE DIGITAL INDICATOR



CC-Link  
DeviceNet

CE DIN 96 RoHS2

- 2000 times/sec. high-speed processing
- Work no. can set up up to 16 types
- Can start measurement even there is no external signal
- Analog monitor output  
Voltage output is proportionate to the input signal making the recording on recorder convenient.  
Approx. 2 V per 1 mV/V strain gauge input
- A variety of interfaces  
RS-232C/ BCD output (Sink type/ Source type)/  
D/A output/ DeviceNet/ CC-Link
- 3.5 inch color LCD module & touch panel  
Setting operation made easy via direct touch on the touch panel.
- Multi calibration function  
Stores calibration values for 4 ch portions and can be selected via touch panel or external signal
- Alarm function  
Monitors if the measured value is abnormal  
- Hi/Lo limit for in comparison setting - Overflow  
- A/D input range - Digital zero regulation value
- Can confirm force pattern before measurement start. (Pre Trigger)

### Waveform display

Input signal from the sensor is displayed as real-time waveform display.

#### Greatly shortens the adjustment time during the machine's start-up.

Assuredly cancels vibration, noise and unwanted inputs. The filtering results can be confirmed from the waveform.

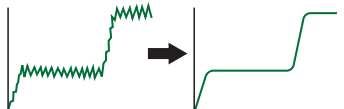

#### Greatly improves the machine's reliability through its in-process operational check.

The machine's operation can be consistently monitored through the waveform and hold points in-process check.

Can also be used when investigating causes of the machine's trouble.

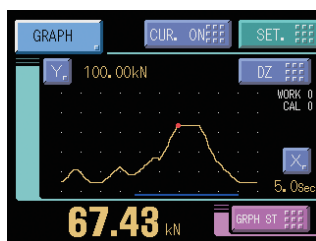

The Hold point is marked in red

### Work selection (multi hold)

This function compares the required points in the waveform with the Hi/Lo limits. F372A stores up to 16 types of settings (settings such as types of holds or Hi/Lo limits) which can be selected via external signals.

#### [Types of holds]

Sample, Peak, Bottom, P-P, Average, Inflection Point, Relative Maximum, Relative Minimum, Relative Difference

#### [Setting of range]

Externally specified range (Peak, Bottom, P-P, Average)  
Externally + time specified range (Peak, Bottom, P-P, Average)  
Level + time specified range (Peak, Bottom, P-P, Average)  
Level (Peak, Bottom)

### Storing of measured data and setting values

Using the special communication software, the setting values can be edited and stored. The same special communication software can also create the CSV output of the measured data.

### Extended functions

Extended functions through simple screen operation

- **Double hold**  
2 types of Hold functions can be simultaneously performed.
- **Previous value comparison**  
The difference generated after deducting the measured value held earlier can be compared with the Hi/Lo limit.
- **Relative value comparison (only during Double hold)**  
The difference (relative difference) between hold value A and hold value B can be compared with the Hi/Lo limit.

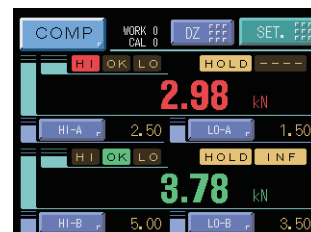

Displayed in the special measuring screen for double hold

#### (Example) A: Peak hold B: Bottom hold

Holds maximum value and minimum value in the specified range. The values are held until the T/H signal is activated.

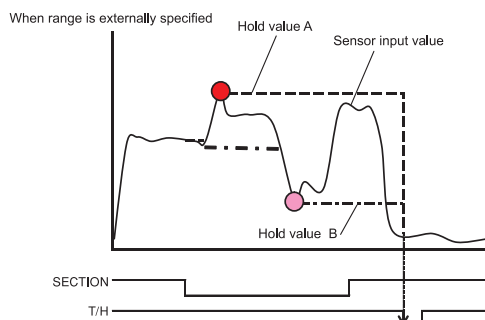

## Specifications

Analog	Excitation voltage	DC 10 V, 2.5 V±5% (depending on settings) Output current: Within 120 mA	
	Signal input range	-3.0 to +3.0 mV/V	
	Accuracy	Non-linearity: Within 0.02% FS±1 digit (at 3.0 mV/V input) Zero drift: Within 0.5 µV/°C RTI Gain drift: Within 0.01%/°C	
	Analog filter	Low pass filter (-6dB/oct.) Selectable from 30, 100, 300, 1 k Hz	
	A/D converter	Speed: 2000 times/sec. Resolution: 24 bit (binary) Approx. 1/30000 at 3.0 mV/V input	
	Analog monitor output	Output level: Approx. 2 V per 1 mV/V input ; Load resistance: 2 kΩ or more	
Display	Display unit	TFT color LCD	
	Display area	71(W) × 53(H) mm	
	Dot structure	320 × 240 dot	
	Measured value	5 digits: -99999 to +99999 Sign: Minus sign on most significant digit	
Hold	1) Sample; 2) Peak; 3) Bottom; 4) P-P; 5) Average; 6) Inflection Point; 7) Relative Maximum; 8) Relative Minimum; 9) Relative Difference; 10) Sample & Peak; 11) Sample & Bottom; 12) Sample & P-P; 13) Sample & Average; 14) Sample & Inflection Point; 15) Sample & Relative Maximum; 16) Sample & Relative Minimum; 17) Sample & Relative Difference; 18) Peak & Bottom; 19) Peak & P-P; 20) Bottom & P-P; 21) Average & Peak; 22) Average & Bottom; 23) Average & P-P; 24) Relative Maximum & Relative Minimum; 25) Relative Maximum & Relative Difference; 26) Relative Minimum & Relative Difference		
Comparison function	Can set 4 different settings from Hi limit, Lo limit, etc		
Calibration value selection	Stores up to 4 types of calibration values that can be interchanged		
External signal	External output signal (8)	HI/LO comparison output (HH, HI, OK, LO, LL)/ RUN output/ Hold end output/ Graph plotting end output Vce = 30 V (max), Ic = 30 mA (max)	
	External input signal (10)	Work selection input/ hold control input/ digital zero input (DZ)/ graph plotting control input/ calibration selection input Ic = 10 mA or less	
Interface	SIF:	2-wire type serial interface	
	232:	RS-232C communication interface	
	BCO:	BCD parallel data output interface (Sink type) (Option)	
	BSC:	BCD parallel data output interface (Source type) (Option)	
	DAV:	D/A converter voltage output (Option)	
	DAI:	D/A converter current output (Option)	
	ODN:	DeviceNet interface (Option)	
CCL:	CC-Link interface (Option)		
Only one option can be installed			
Option	ISC: I/O Source board		
General specifications	Power supply voltage	DC 24 V (±15%)	
	Power consumption	5 W typ.	
	Inrush current typ.	55 A, 1 msec (cold start at room temperature)	
	Operation condition	Temperature:	Operation temperature -10 to +40°C Storage temperature -20 to +60°C
		Humidity:	85% RH or less (non-condensing)
	External dimension	96(W) × 96(H) × 138(D) mm (not including projections)	
	Weight	Approx. 1.0 kg	

Attachments	FCN series I/O connector (with cover) .....	1	
	Operation Manual .....	1	
	Analog I/O connector terminal block (Already mounted on the main unit) .....	1	
	BCD output connector (when BCD output option is selected) .....	1	
	Mini driver (when D/A converter option is selected) .....	1	
	DeviceNet connector (when DeviceNet option is selected) .....	1	
	CC-Link connector (when CC-Link option is selected) .....	1	
	Optional accessories	CA372-I/O: Cable with FCN connector at one-end 3 m	
		CA600-BCDCNV: FCN connector 32p-57·36p cabire cable 0.3 m	
		CA81-232X: miniDIN-D-Sub9p cross cable 1.5 m	
		CN50: FCN series I/O connector (with cover)	
		CN51: BCD output connector	
CN55: FCN series I/O connector (with diagonal cover)			
CN60: Round DIN 8p connector for RS-232C			
CN71: CC-Link connector			
CN72: Double row connector for CC-Link			
CN80: Analog I/O connector terminal block (Same accessory as the attached one)			
CND01: DeviceNet connector			
DTC2: Special case			
GMP96x96: Rubber packing			
TSU03: DC Lightning surge unit			
CE marking certification	EMC Directive EN61326-1		

\* Please note that there are possibilities of individual differences in a color tone on display devices such as LEDs, fluorescent display tubes and LCDs due to manufacturing process or production lots.

## Structure of product code

F372A    

①            ②            ③

### ① Standard unit

### ② I/O output

Sign	Output type
Standard	Sink type (NPN output)
ISC	Source type (PNP output)

### ③ Interface

Sign	Interface
Standard	SI/F, RS-232C

↓ One optional interface can be added in addition to the standard interface.

BCO	BCD output (Sink type)
BSC	BCD output (Source type)
DAV	D/A converter (Voltage output)
DAI	D/A converter (Current output)
ODN	DeviceNet
CCL	CC-Link

DTC2: Case for F372A (with AC power supply)

Unit: mm

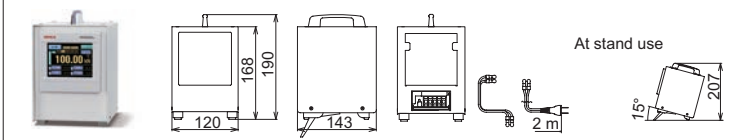

At stand use

2 m

15°

207

## External dimension

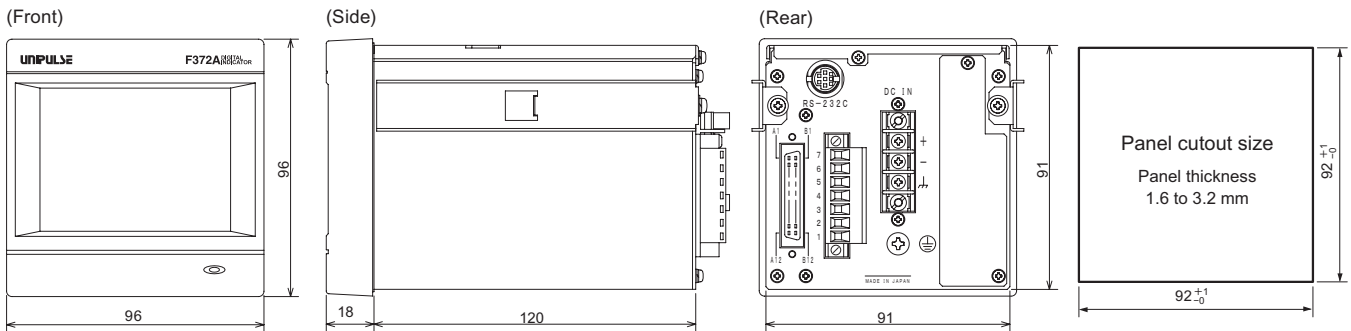

Unit: mm